

HF Compliant 3168 SERIES HDMI FEMALE UPRIGHT TYPE

REV	DATE	DESCRIPTION	ECN NO.	NAME
A	11.01.12	NEW RELEASE		sky.xu
B	11.04.20	△CHANGE HOUSING STRUCTURE	CECR11006136	sky.xu
C	13.04.28	△CHANGE ORDER INFORMATION	CECR13007497	YAI
D	13.07.30	△CHANGE DRAWING	CECR13007729	YAI

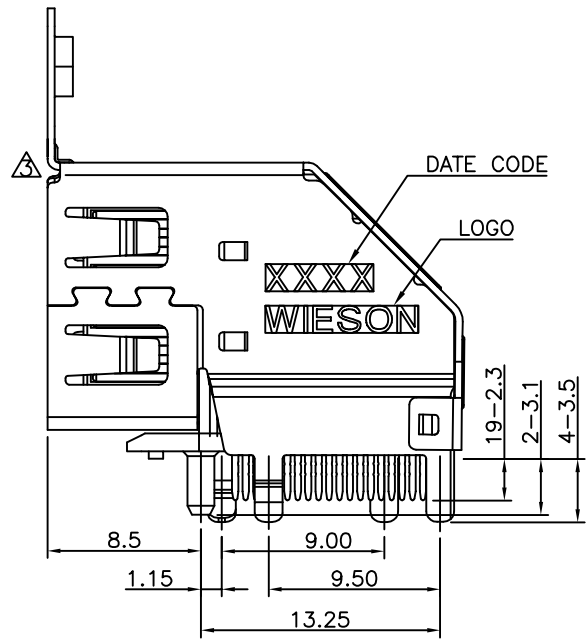
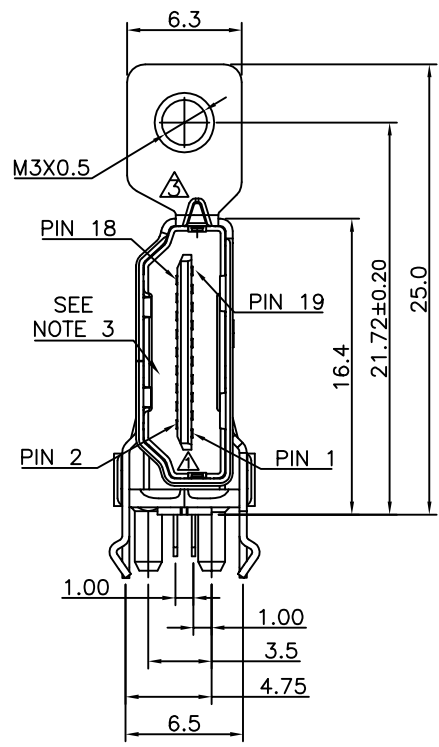
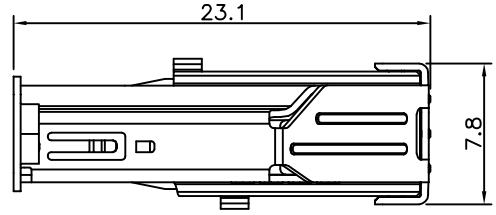

NOTES:

- MATERIAL :**
 TERMINAL : COPPER ALLOY .
 SHELL : COPPER ALLOY .
 HOUSING : THERMOPLASTIC(UL94V-0) , BLACK.
- PLATING :**
 TERMINAL : Au PLATED ON CONTACT AREA(SEE ORDER INFORMATION),100u" Sn PLATED ON SOLDER TAIL AREA, BOTH OVER 50u" Ni UNDERPLATED OVERALL.
 SHELL : 100u" SOLDERABLE Ni OVERALL.
- INTERFACE DIMENSIONS PER HDMI SPECIFICATION VERSION 1.3a**
- PACKING : TRAY (P-G3168-50-001)**
- ORDER INFORMATION : G3168-50 XX XX XX -H0**
 ① ② ③

- △ 00 : W/O SCREW;SPECIAL DIP
- ① 01 : W/ SCREW;SPECIAL DIP
- 02 : W/O SCREW;SHORT DIP
- ② 00 : W/O WIESON LOGO
- 01 : W/ WIESON LOGO
- ③ 01 : Au FLASH ;
- 02 : 3u" Au ;
- 03 : 15u" Au ;
- 04 : 30u" Au .

GENERAL TOLERANCE	WIESON TECHNOLOGIES CO., LTD WIESON	PART NO.: G3168-50XXXXXX-H0	
		DRAWN BY sky.xu (WSC)	DRAWING NO. G3168-50XXXXXX-H0
X.X = ±0.20	CHECKED BY JACK	DRAWING SIZE 2.5 : 1 A4	
X.XX = ±0.15	APPROVED BY JACK	UNIT	mm
X.X* = ±3*	SORTING NO. WSC	PAGE	1 OF 2

HF Compliant 3168 SERIES HDMI FEMALE UPRIGHT TYPE

REV	DATE	DESCRIPTION	ECN NO.	NAME
A	11.01.12	NEW RELEASE		sky.xu
B	11.04.20	△CHANGE HOUSING STRUCTURE	CECR11006136	sky.xu
C	13.04.28	△CHANGE ORDER INFORMATION	CECR13007497	YAI
D	13.07.30	△CHANGE DRAWING	CECR13007729	YAI

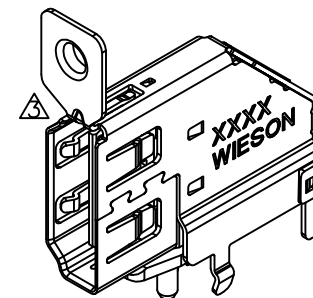
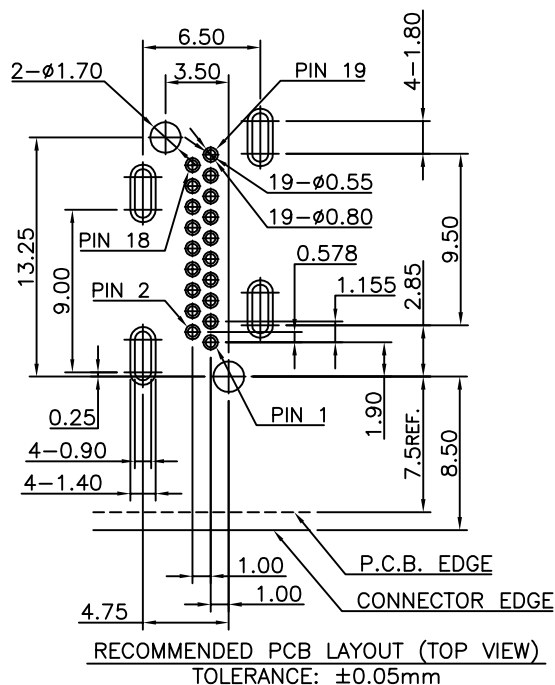

W/ SCREW,SPECIAL DIP

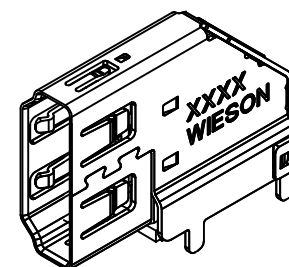

W/O SCREW,SHORT DIP

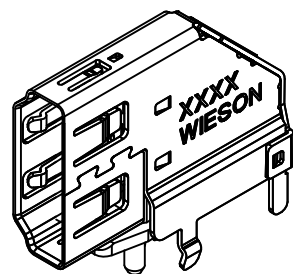

W/O SCREW,SPECIAL DIP

GENERAL TOLERANCE	WIESON TECHNOLOGIES CO., LTD	PART NO.:	G3168-50XXXXXX-H0
X.X = ±0.20	WIESON	DRAWN BY	sky.xu (WSC)
X.XX = ±0.15		CHECKED BY	JACK
X.X* = ±3*		APPROVED BY	JACK
		DRAWING NO.	G3168-50XXXXXX-H0
		DRAWING SIZE	2.5 : 1 A4
		UNIT	mm
		PAGE	2 OF 2
		SORTING NO.	WSC