

HF Compliant

3168-SERIES HDMI SMT TYPE WITH FRONT SPRING

REV	DATE	DESCRIPTION	ECN NO.	NAME
A	13.08.02	PROPOSAL		JIN
B	14.01.13	NEW RELEASE		King
C	19.04.19	▲ ADD TYPE		GAVIN

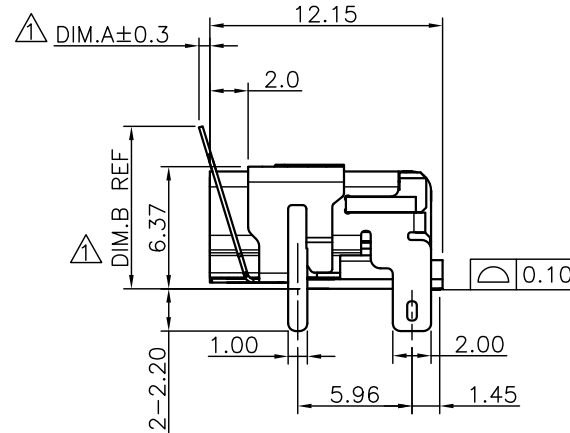
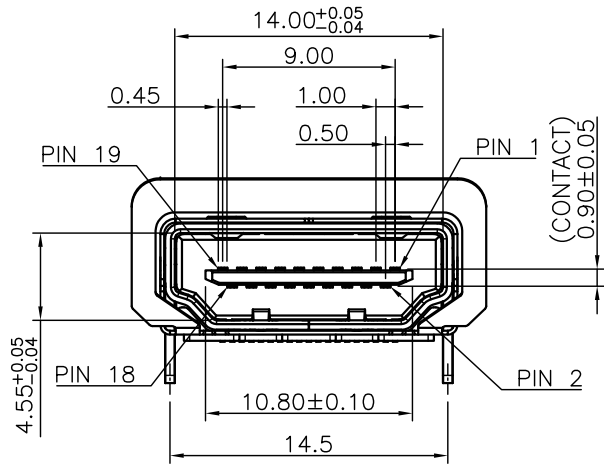
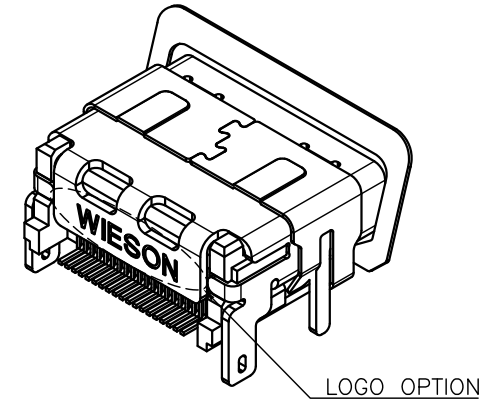
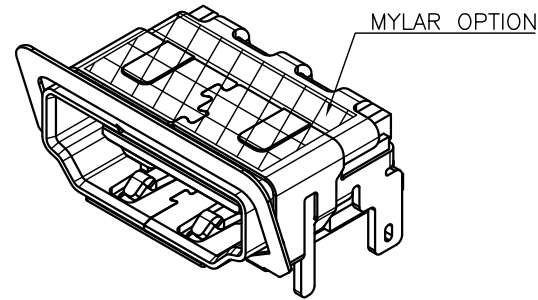
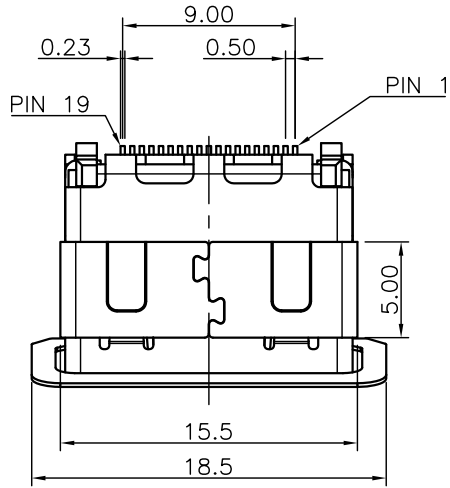

GENERAL TOLERANCE X.X = ±0.20 X.XX = ±0.15 X.X* = ±3*	WIESON TECHNOLOGIES CO., LTD WIESON	PART NO.: G3168-70XXXXX-H0		
	DRAWN BY	JIN	DRAWING NO.	G3168-70XXXXX-H0
	CHECKED BY	YXJ	DRAWING SIZE	2.5 : 1 A4
	APPROVED BY	JIM	UNIT	mm
	SORTING NO.	WSC	PAGE	1 OF 2

ISSUED

HF Compliant

3168-SERIES HDMI SMT TYPE WITH FRONT SPRING

REV	DATE	DESCRIPTION	ECN NO.	NAME
A	13.08.02	PROPOSAL		JIN
B	14.01.13	NEW RELEASE		King
C	19.04.19	▲ ADD TYPE		GAVIN

NOTE :

- 1.MATERIAL :
 - (1)TERMINAL : COPPER ALLOY
 - (2)SHELL : COPPER ALLOY
 - (3)HOUSING : HIGH TEMPERATURE THERMOPLASTIC (UL94-0),COLOR:BLACK.
 - (4)FRONT SPRING : STEEL(STAINLESS)
 - (5)MYLAR: POLYESTER-IMIDE FILM.
- 2.PLATING :
 - (1)TERMINAL: SELECTIVE Au PLATED ON CONTACT AREA (SEE ORDER INFORMATION), Sn PLATED ON SOLDER TAIL AREA, BOTH OVER Ni UNDERPLATED OVERALL.
 - (2)SHELL: WELDABLE Ni PLATED OVERALL.
- 3.PACKING: (SEE ORDER INFORMATION)
- 4.ORDER INFORMATION : G3168-70 $\text{\textcircled{00}}$ $\text{\textcircled{01}}$ $\text{\textcircled{02}}$ $\text{\textcircled{03}}$ $\text{\textcircled{04}}$ -H0

- $\text{\textcircled{00}}$: W/O MYLAR
- $\text{\textcircled{01}}$: W/ MYLAR

- $\text{\textcircled{00}}$: W/O LOGO ; PACKING T&R
- $\text{\textcircled{01}}$: W/ LOGO ; PACKING T&R
- $\text{\textcircled{02}}$: W/O LOGO ; PACKING TRAY
- $\text{\textcircled{03}}$: W/ LOGO ; PACKING TRAY

- $\text{\textcircled{0}}$: DIM.A=0.6 , DIM.B=8.48
- $\text{\textcircled{1}}$: DIM.A=2.3 , DIM.B=7.62

- $\text{\textcircled{1}}$: Au FLASH ON CONTACT AREA
- $\text{\textcircled{2}}$: 3u"Au ON CONTACT AREA
- $\text{\textcircled{3}}$: 5u"Au ON CONTACT AREA
- $\text{\textcircled{4}}$: 15u"Au ON CONTACT AREA
- $\text{\textcircled{5}}$: 30u"Au ON CONTACT AREA

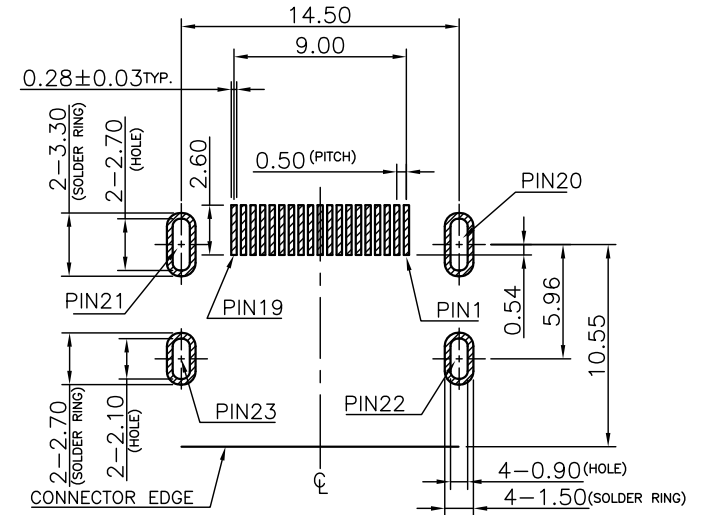

RECOMMENDED PCB LAYOUT (TOP VIEW)
TOLERANCE: ±0.05mm

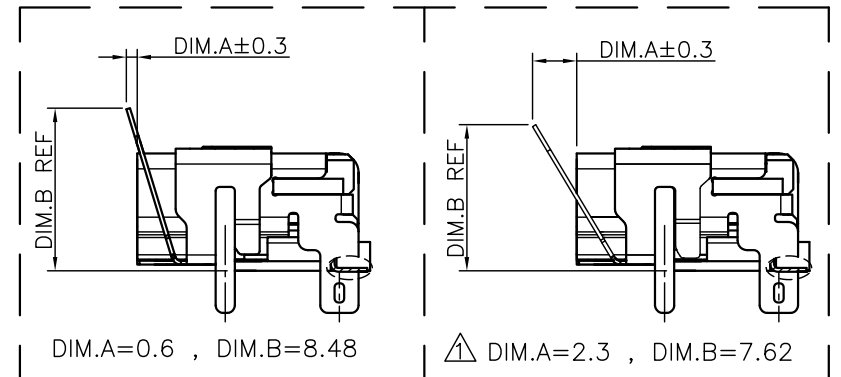

GENERAL TOLERANCE X.X = ±0.20 X.XX = ±0.15 X.X* = ±3*	WIESON TECHNOLOGIES CO., LTD WIESON	PART NO.: G3168-70XXXXX-H0		
	DRAWN BY	JIN	DRAWING NO.	G3168-70XXXXX-H0
	CHECKED BY	YXJ	DRAWING SIZE	2.5 : 1 A4
	APPROVED BY	JIM	UNIT	mm
	SORTING NO.	WSC	PAGE	2 OF 2

ISSUED

[ARTICLE:044033 V6]