

RoHS Compliant

7415 SERIES HDMI + HDMI CONNECTOR

REV	DATE	DESCRIPTION	ECN NO.	NAME
A	12.12.10	PROPOSAL		Nate.H
A1	13.02.25	△MODIFY		Nate.H

NOTE: 1.MATERIAL :
 HOUSING : HIGH TEMPERATURE PLASTIC, UL94V-0 COLOR:BLACK
 TERMINAL : COPPER ALLOY.
 SHELL : COPPER ALLOY.
 GROUND : STEEL

2.PLATING :
 TERMINAL : Au PLATED ON CONTACT AREA, Sn PLATED ON SOLDER TAIL AREA, BOTH OVER Ni UNDERPLATED OVERALL.
 SHELL : WELDABLE Ni OVERALL.

3.PACKING : TRAY.

4.ORDER INFORMATION: G7415-020000 X X -00

UPPER HDMI PLATING
 0 : GOLD FLASH
 1 : 3u" Au
 2 : 15u" Au
 3 : 30u" Au

BOTTOM HDMI PLATING
 0 : GOLD FLASH
 1 : 3u" Au
 2 : 15u" Au
 3 : 30u" Au

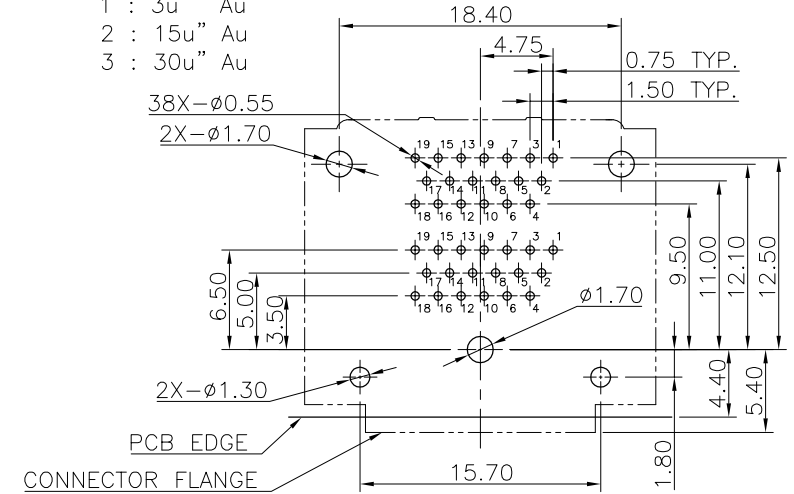
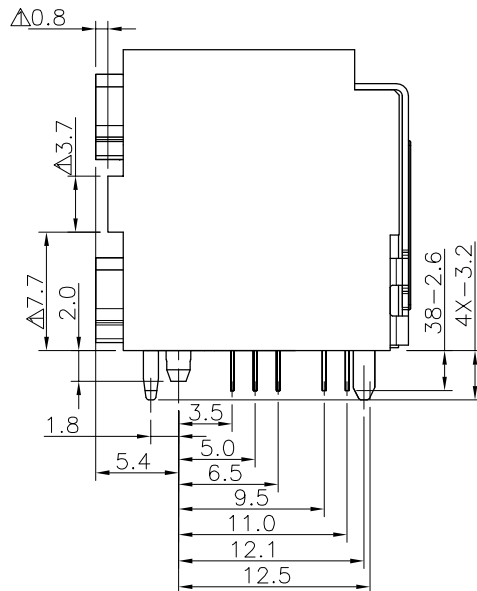
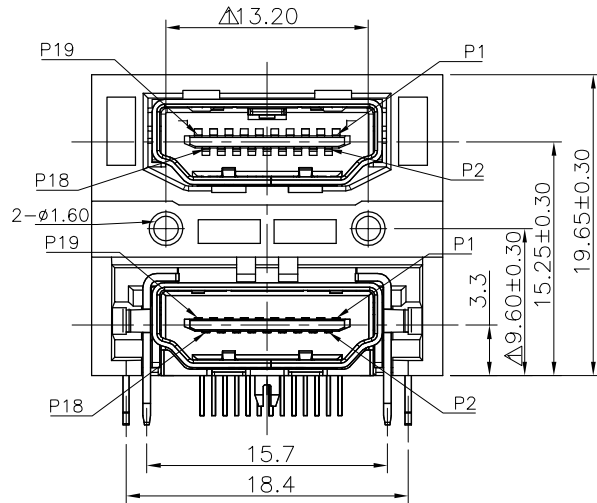
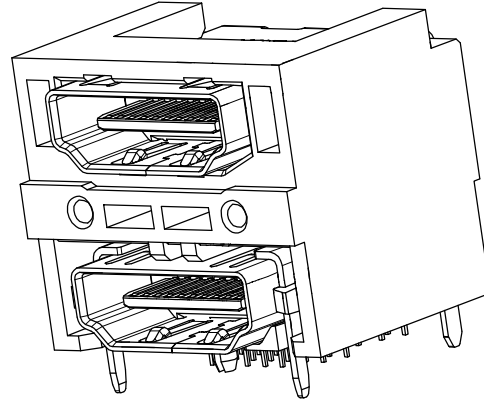
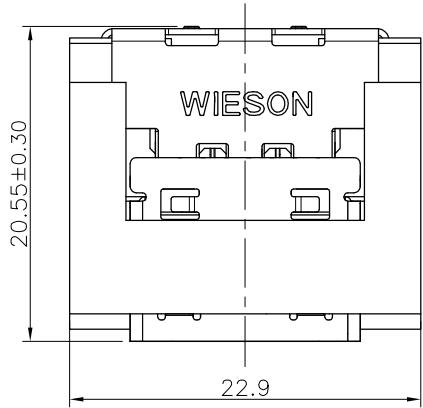

RECOMMEND PCB LAYOUT (TOP VIEW)
 TOLERANCE: ±0.05mm

GENERAL TOLERANCE		WIESON TECHNOLOGIES CO., LTD		PART NO.:	
X.X	=±0.20	DRAWN BY Nate.H CHECKED BY HSIEN APPROVED BY FRED LEE		G7415-020000XX-00	
X.XX	=±0.15			DRAWING NO. G7415-020000XX-00	
X.X"	=±3'			DRAWING SIZE 2 : 1 A4	
		SORTING NO. WSC		UNIT mm	
		PAGE 1 OF 1			