



STC1104 SERIES ~ SMD Toroidal

Common Mode Choke & Transformers



RoHS Compliant

PART NUMBERING SYSTEM

STC	1 1 0 4	—	1 0 0 M	—	LF
TYPE	DIMENSIONS		IMPEDANCE		LEAD FREE

SHAPES AND DIMENSIONS

UNIT : mm

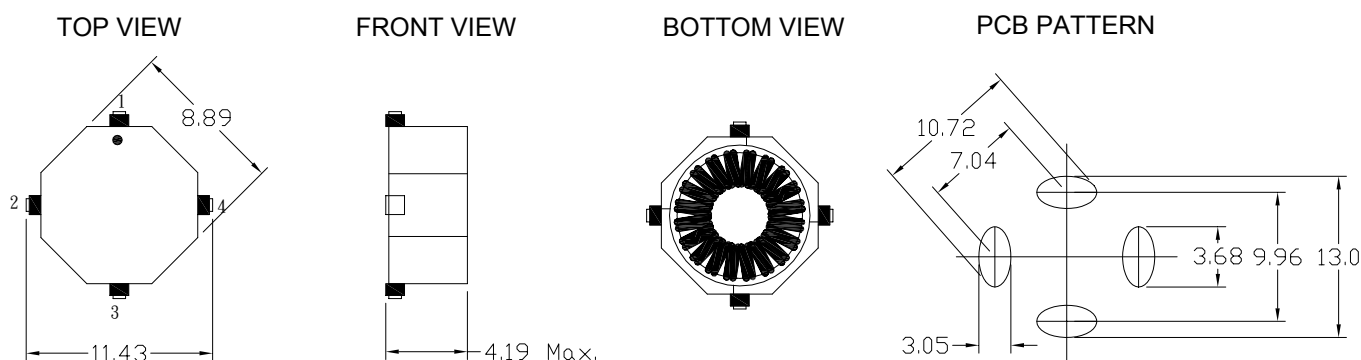

SPECIFICATION TABLE

TYPE	Parallel Ratings					Series Ratings			
	PART NUMBER	INDUCTANCE (μH)	OCL±20% (μH)	Full Load Inductance uh min.	Current (A)	DCR (Ω) (Max.)	OCL±20% (μH)	Full Load Inductance uh min.	Current (A)
STC1104-R47M-LF	0.47	0.42	0.31	5.50	0.005	1.67	1.25	2.75	0.021
STC1104-R68M-LF	0.68	0.60	0.43	5.10	0.006	2.40	1.74	2.55	0.025
STC1104-1R0M-LF	1.0	1.07	0.73	4.50	0.008	4.28	2.92	2.25	0.032
STC1104-2R2M-LF	2.2	2.02	1.36	3.40	0.013	8.08	5.44	1.70	0.054
STC1104-4R7M-LF	4.7	4.83	3.37	2.00	0.040	19.31	13.47	1.10	0.161
STC1104-8R2M-LF	8.2	8.08	5.31	1.80	0.052	32.33	21.23	0.90	0.207
STC1104-100M-LF	10	9.62	6.23	1.70	0.057	38.48	24.94	0.85	0.227
STC1104-150M-LF	15	15.03	9.62	1.40	0.087	60.12	38.47	0.70	0.348
STC1104-220M-LF	22	20.46	14.12	1.00	0.158	81.83	56.47	0.50	0.634
STC1104-270M-LF	27	25.40	17.07	0.96	0.177	101.6	68.29	0.48	0.708
STC1104-330M-LF	33	32.33	22.27	0.80	0.250	129.3	89.06	0.40	1.001
STC1104-500M-LF	50	50.52	33.57	0.70	0.316	202.1	134.2	0.35	1.263
STC1104-680M-LF	68	68.40	43.65	0.66	0.373	273.6	174.6	0.33	1.490
STC1104-101M-LF	100	99.01	63.64	0.54	0.557	396.0	254.5	0.27	2.227
STC1104-151M-LF	150	150.7	96.64	0.44	0.844	602.8	386.5	0.22	3.376
STC1104-201M-LF	200	198.4	130.7	0.36	1.208	793.6	523.1	0.18	4.831
STC1104-301M-LF	300	299.8	190.0	0.32	1.525	1199.4	760.1	0.16	6.100

● Operating temperature range -40°C to +85°C. Electrical specifications at 25°C .



STC1104 SERIES ~ SMD Toroidal

Common Mode Choke & Transformers



RoHS Compliant

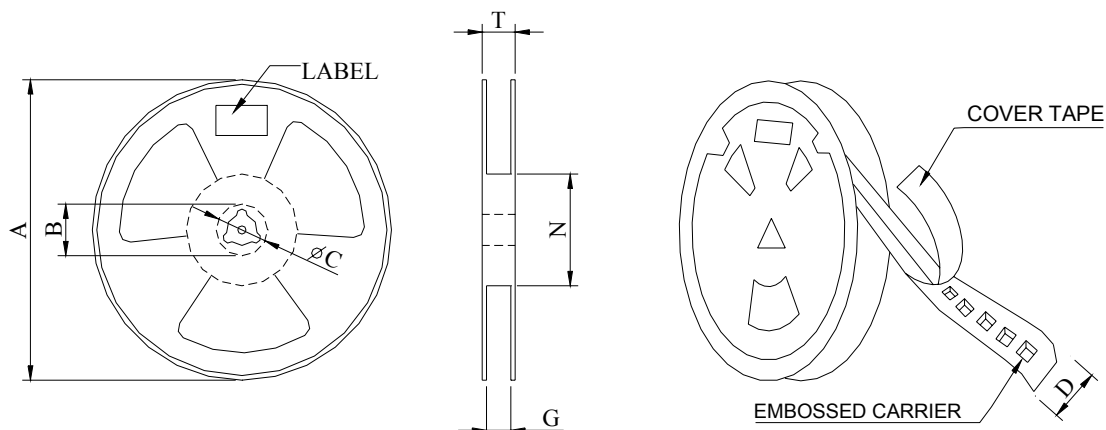

*CARRIER TAPE WIDTH : D

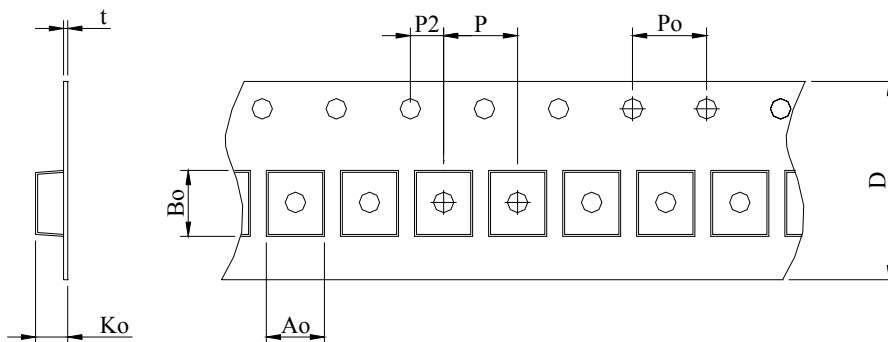

DIMENSIONS (m/m)

Q'TY (PCS)	A	B	C	D	G	N	T	Ao	Bo	Ko	t	P	Po	P2
1000	330	—	13.5 ±0.5	24.0 ±0.3	—	75.0 ±2.0	—	9.3	9.3	4.6 ±0.1	0.4 ±0.1	12.0 ±0.1	4.0 ±0.1	—