



Product Specification

Ningbo East Electronics Limited
NO. 88 East Jinhui Road, Yinzhou Ningbo 315100, P.R.China
<http://www.east-mingtao.com>

Product Name:	Ultrasonic Annunciator
Part Number:	W-06A
Version:	1.01
Date:	2015-2-12
Note:	

Company passed ISO 9001 / ISO TS16949 / ISO 14001 Certifications

Revision History

Rev.	Description	Author/Date	Checked By	Approver
1.01	Quality Certificate Symbol revised	刘宁 2015-2-12	汤礼东	王建成
1.0	Released	汤礼东 2012-2-8	张春雷	王建成

1. Part Number W-06A

2. Dimension Drawing (Unit: mm)

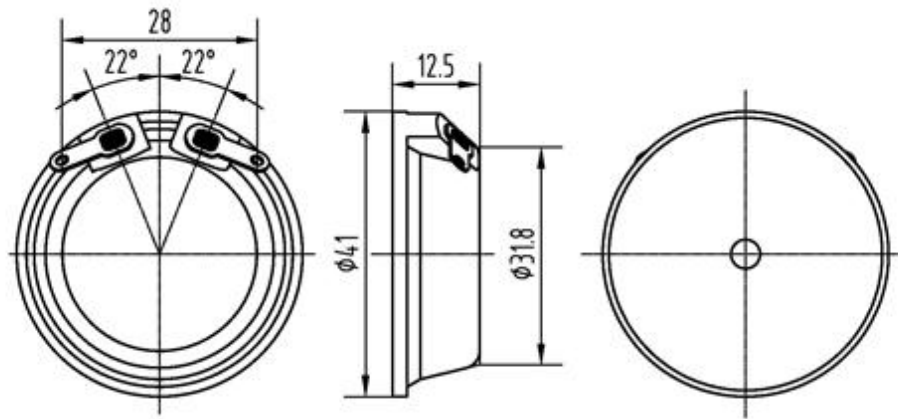

3. Specification

No.	Item	Specification
3-1	Min. Sound Pressure Level	90dB/22±1kHz/2.83Vrms sine wave /50cm
	Min. Sound Pressure Level	90dB/40±3kHz/2.83Vrms sine wave /50cm
3-2	Rated Voltage	2.83Vrms
3-3	Max. Operating Voltage	10Vrms
3-4	Frequency Range	4~50kHz
3-5	Operating Temperature	-20~+70°C
3-6	Case Material /Color	Fire-resistance ABS/Black
3-7	Weight	6.2g
3-8	Pin Strength	More than 10N

NOTES:

Test should be made under the conditions of room temperature ($20\pm 10^{\circ}\text{C}$), normal humidity ($60\pm 20\%$) and normal atmospheric pressure. In this case, however, that the judgment is questionable, the test conditions are to be changed to room temperature $20\pm 2^{\circ}\text{C}$, relative humidity 60~70% and normal atmospheric pressure

4. Typical Frequency Response Curve

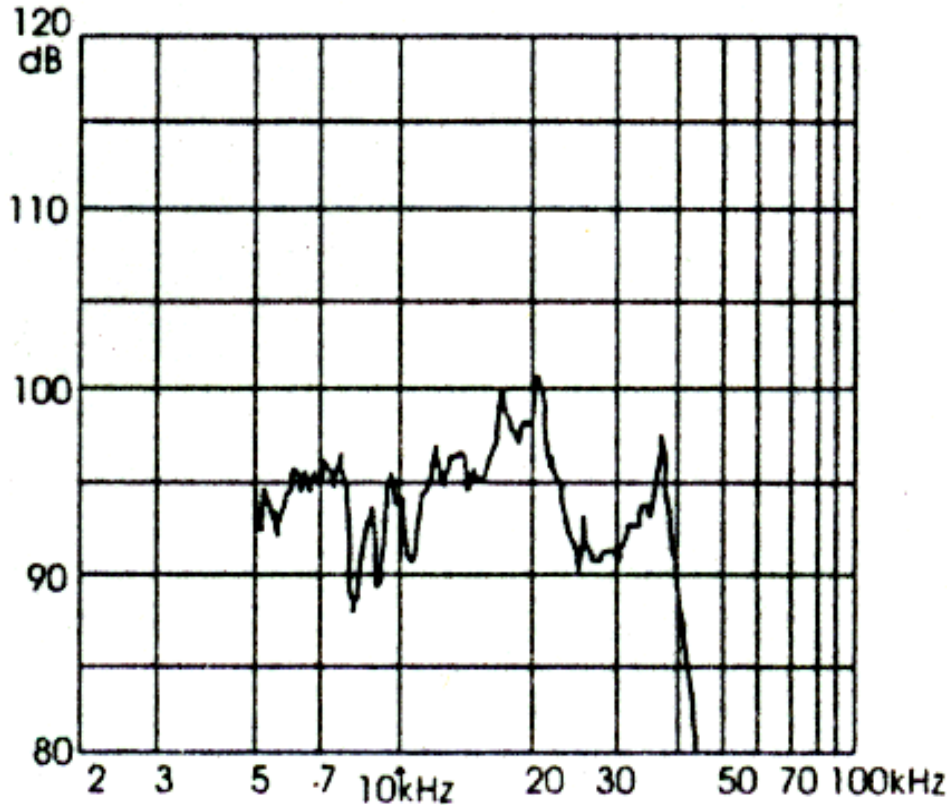

Note: Input Voltage 2.83Vrms sine wave
Distance 50cm

5. Reliability Test

No.	Item	Method of Test	Tolerance after Testing
5-1	Operating Temperature	-20~+70°C	Sound pressure level initial value ± 10 dB
5-2	Storage in high temperature	Storage in +70°C test box 96 hours then exposed to the room temperature for 2 hours	
5-3	Storage in low temperature	Storage in -20°C test box 96 hours then exposed to the room temperature for 2 hours	
5-4	Life test in the room temperature	Operate the product continuously 5 seconds on 5 seconds off 300 hours at rated voltage	
5-5	Temperature / humidity cycle test	Storage in +40°C, 93 \pm 3%RH test box 96 hours then exposed to the room temperature for 2 hours	
5-6	Temperature (high and low) cycle test	Conduct the test for 5 cycles without applying power then expose to the room temperature for 2 hours.(See Figure 5-6)	

5-7	Vibration test	Conduct the test for the directions of X Y and Z for 0.5 hour each (total 1.5 hours). To-and Fri sweep time(from 10 to 55Hz and then 55 to 10) under single amplitude of 0.75mm is 3 minute, then expose to the room temperature for 2 hours	
5-8	Soldering heat resistance test	Dip the connecting pins in soldering at $260\pm 5^{\circ}\text{C}$ for 10 ± 1 seconds	
5-9	Test of soldering	Dip the connecting pins in soldering at $230\pm 5^{\circ}\text{C}$ for 3 ± 0.5 seconds	Solder shall be attached around over 95% of the dipped portion

Figure 5-6

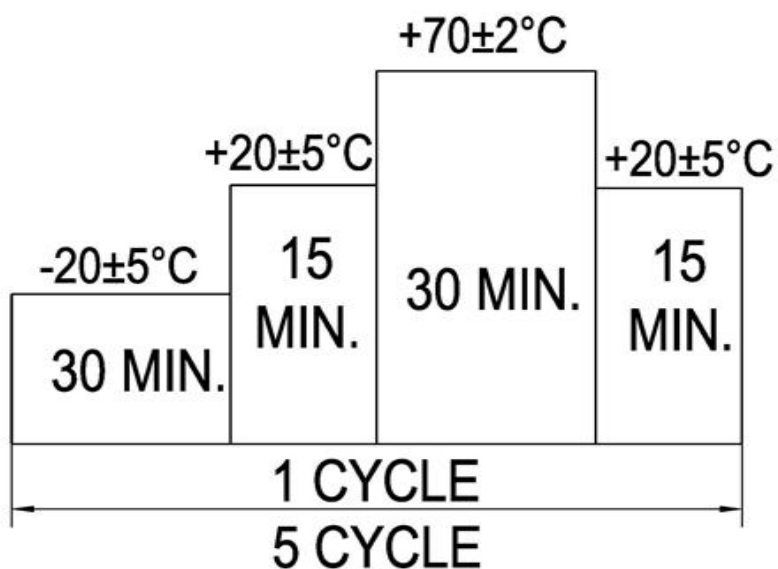

6. Electrical Testing Method

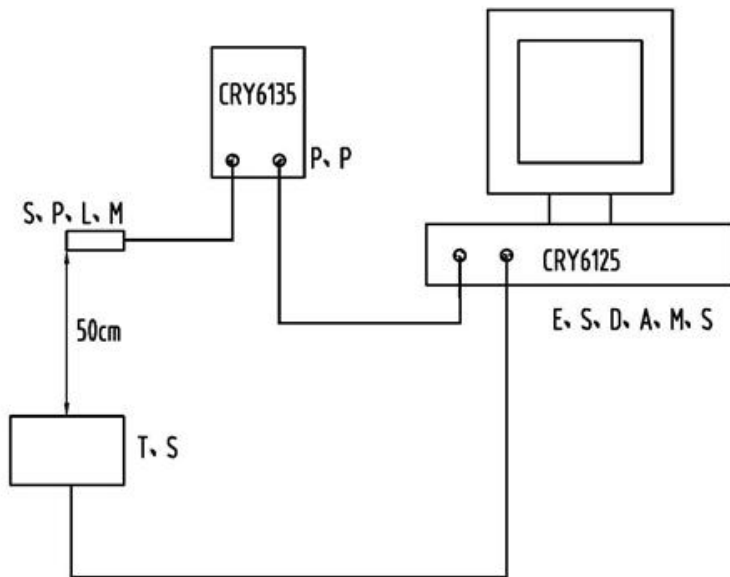

S.P.L.M	Sound Pressure Level Meter
T.S	Testing Sample
P.P	Preamplifier Power
E.S.D.A.M.S	Electric Sound Device Analyzer Meter Series

7. Packing Information

Packing: 1000 pcs per export carton

Carton Size: 47× 30.5× 31 cm

G. Weight: 7.8 kgs N. Weight: 6.2 kgs